



**Instructionmanual  
for installation  
and operation  
F&H Crone Excellent  
Fluegas condenser**

**ASME CODE VIII div.1 Stamped**

<b>Type</b>	:	<b>L ..0C ASME</b>
<b>Condensor serial number</b>	:	<b>2326.</b>
<b>User</b>	:	
<b>Date of issue</b>	:	
<b>Handed to</b>	:	

Revision 2023-issue 0

## **GENERAL**

The Condenser, you have just received has been designed and manufactured with the greatest possible care in our factory in order to meet the requirements.

To ensure that it functions properly during a long life, it is important that it be installed, started and operated with equal care. That is why this booklet has been provided. You should read it carefully and follow the instructions.

## **Guarantee**

The delivered condenser is covered with a guarantee period as described in the General Terms and Conditions of Delivery for the Metal and Electrical Engineering Industry, issued by the association for the Metal and Electrical Engineering Industry FME, which we will send to you free of charge upon request.

The period starts after the commissioning of the boiler, but no later than 3 months after delivery.

Any defects must be reported to us immediately. Problems that arise due to non-application or careless application of the instructions in this book are not covered by the warranty.

## **Warning**

No lids or flanges may be detached or removed during operation.

The condenser must also be earthed to prevent discharge of static electricity.

## **Fuel**

Depending on the burner installed, the condenser is suitable for burning natural gas, LPG or butane. For further details, see the burner instructions.

## **A. OPERATING**

### **A.1 Areas of application**

The flue gas condenser is used to cool the flue gases from natural gas-fired plants. This concerns hot water boilers where the condenser is placed behind / on. The energy that is released from these installations is used to heat water. The maximum inlet temperature of the flue gases in the condenser is 210 ° C.

The maximum water temperature is 95 ° C, but that will not be achieved in practice because the flue gases will not condense. The condenser is part of a closed system with a permitted maximum water pressure of 3 bar.

### **A.2 Operation, general**

The flue gas condenser is installed behind a gas-fired boiler. All flue gases coming from the boiler are led through the condenser where they are cooled. The heat released from this process heats the water in this closed system. The remaining highly cooled flue gasses disappear through the chimney or can still be tapped for CO<sub>2</sub> dosing or other applications. All this depends on the installation. The condenser is tested with cold water at 4 bar before delivery at the factory to ensure that it is not leaking. The normal working pressure is usually around 1 bar. Maximum permitted working pressure is 3 bar.

### **A.3 Operation of the flue gas condenser**

The flue gas condenser is equipped with a bypass channel as standard. When the bypass channel is closed, the flue gases are led through the condenser block. The burner fan then has to deal with a greater resistance and must be able to absorb this pressure difference. That is why the choice of fan capacity is important. The pressure drop in the condenser is protected by a pressure switch. If the flue gases cannot be passed through the condenser, the diverter valve must be turned with the handle to close the condenser block. In cases where gas / oil burners are used, this position must be protected by means of a limit switch.

If oil is used as fuel, the condenser must be closed. If heavy oil is burned or if there is a long-term heating on light oil, it is not possible to burn via the bypass channel. An additional outlet must then be created to completely guide the flue gases around the condenser.

A pump ensures that the water is pumped through the condenser. If the water flow is not sufficient, overheating can occur. That is why it is important to ensure sufficient water flow over the condenser. The connections of the condenser are also designed for this.

The temperature is monitored with a maximum thermostat. These protective provisions must be included in the starting conditions of the boiler-burner combination. On the water side, the condenser is protected by a blow-off protection that opens when the pressure becomes too high.

The flue gas condenser is a closed device with an inspection hatch in the smoke tray for inspection and maintenance.

## **B. INSTALLATION**

### **B.1 Integration of the condenser in the system**

The F&H Crone condenser is made from corten steel. The use of this material guarantees a long service life. It is necessary that rapid temperature fluctuations are avoided. To prevent leaks, the rising and falling temperatures of the condenser water must therefore not exceed 2 ° C per minute.

### **B.2 Delivery**

The flue gas condenser is supplied as standard with a diverter valve, 4-leg smoker, bypass channel, outlet channel to chimney, steam trap and hose. The smoke tray is already attached to the F&H Crone boiler or is supplied separately with 4 (adjustable) legs.

### **B.3 Regulations**

Installation must be in accordance with applicable national and regional regulations. The discharge of the condensed water and flue gases must comply with the provisions of NEN-EN 3028. NEN-EN 1010 applies to the electrical installation.

### **B.4 Set up**

The flue gas condenser must be installed in a frost-free covered area in such a way that it is possible to carry out inspection and maintenance on the device. The required free space on the inspection side is at least 1 meter.

With a separately supplied condenser, the loose counter flange must be welded to the boiler smoke tray. The center height of the flange and the inlet channel of the condenser must exactly match. Adjustment of this can be done by using the adjustable legs to be welded at the right height underneath.

### **B.5 Installation of safety devices**

Mount the pressure and limit switch, thermostat, blow-off safety and thermometers in the location as shown in Appendix 1. It is only permitted to use the safety equipment supplied with the condenser.

The maximum thermostat protects the installation against overheating. This can happen because the pump is not running and there is not enough water flow over the condenser. The maximum permitted water temperature is 95 ° C.

It is possible that the resistance of the flue gases in the condenser block increases due to contamination. This has an effect on the operation of the burner. The resistor is protected by a pressure switch. This must be set to 100 Pa above the maximum operating pressure. Furthermore, the overpressure protection must be set to 3 bar (= maximum operating pressure).

The position of the shuttle valve is protected by the limit switch. This must be adjusted in such a way that during temporary oil firing the flue gases are diverted via the bypass channel.

Note: the protection components must be included directly in the safety loop to the burner of the boiler (fail safe).

### **B.6 Condens bin**

A condens bin is supplied with the condenser to collect the condensate. Fit the condensate pipe (s) to the connection at the bottom of the smoke tray. The condensate pipe should end up approximately 5 cm above the bottom of the condens bin as this acts as a water trap. The overflow connection must be connected to a drain sump. Local legislation sometimes requires that water discharged into the sink must be pH neutral.

### **B.7 Watersided connections**

Ensure that the blow-off safety is properly connected to the drain system via an "open" connection. Connect the pipework to the condenser with the correct bolts and nuts. The water circuit of the condenser must be connected in such a way that there is always overpressure in this system. This means that the suction side of the pump must not be directly connected to the condenser unless the minimum overpressure in the system is higher than 1.5 bar.

The pipes to be connected to the condenser must be laid in such a way that, due to expansion or otherwise, no forces are exerted on the condenser connections.

No changes / modifications may be made to the condenser without the manufacturer's permission.

### **B.8 Fluegas**

The flue gas discharge on the condenser must be carried out in accordance with national and regional requirements to be mounted.

Maximum permitted weight load due to the flue gas discharge on the condenser is 250 kg. The flue gas discharge must be properly labeled to prevent wind influences. Also, lateral forces or movements of any CO<sub>2</sub> connection ducts on the flue gas outlet must be prevented by applying sufficient supports.

Diameter of the flue gas ducts are shown in the overview of Appendix 3.

## **C. COMMISSIONING**

### **Check points**

Before the installation is put into operation, the following points must be checked:

- Is the system filled with water?
- Has the system been bled?
- Do the pressure and temperature switches work?
- Is the shuttle valve in the correct position?
- Is the steam trap filled with water?
- Is water flowing through the condenser and are all valves pointing in the right direction?
- If one of the protections is activated, restore it and reset the system.
- Read the gas pressure on the pressure switch and set it to this value + 100 Pa

## **D. MALFUNCTION**

Disruptions are visible on the switch panel provided that this is included in the purchase. After the cause of the malfunctions has been found and repaired and the reset button has been pressed, the installation can be put back into use.

## **E. MAINTENANCE**

### **E.1 General**

The self-cleaning process due to the falling condensate on the heat exchanger ensures very little contamination of the device. The precipitating condensation in the Corten steel smoker can cause iron oxide, which is partly transported to the steam trap. The safety devices must also be checked at least once a year, for example in combination with burner maintenance.

### **E.2 Cleaning**

The condens bin must be cleaned regularly (at least 4x a year). The Oxides and dirt on the bottom of the fluegasbox must be removed at least once a year. If the heat exchanger is contaminated, it must be cleaned. The degree of pollution can be measured by the increase in resistance in the flue gas circuit. Access to the condenser can be easily and quickly via the inspection hatch. If necessary, contact your installer or boiler maintenance company.

## **OPERATION AND MAINTENANCE INSTRUCTION**

### **Boiler and condenser water quality**

The boiler and condenser water must meet the requirements stated in Appendix 3. The water may need to be processed before it is added to the installation. An expert must be advised for this purpose.

### **Mandatory checks**

During the use of the condenser, the amount of water that may be required to top up the installation must be checked. In the event of excessive topping up, there is a leak and this must be detected immediately and remedied, this to prevent oxygen corrosion, among other things. Flue gas-side leaks occurring during use must also be rectified immediately.

The flue gas temperature must not exceed 100°C above the boiler water temperature and must be measured regularly. When it rises, the boiler pipes must be cleaned.

Regularly check the operation of the condens bin (if present) and the presence of sediment in it.

Depending on the conditions of use, but at least twice a year, the boiler must be checked for the following:  
**Ensure adequate ventilation when entering the condenser.**

- condition of gaskets and inspection hatch;
- contamination and corrosion of the flue gas-side surfaces;
- condition of the aluminum fins;
- operation of the safety valve (s) or relief valve (s) and other safety devices.

In the case of deviations, an expert must be consulted.

### **Burnerfan**

The intake by the burner fan of air, contaminated with mists, components of plant protection products or other chemicals, can cause serious and unstoppable corrosion in the condenser and must therefore be excluded at all times.

### **Operation and maintenance burner and boiler controls**

For the operation and maintenance of the burner and other equipment, explicit reference is made to instructions from the relevant suppliers.

### **Protection of the condenser against the weather.**

During the annual inspection, care must also be taken that the condenser is still well protected against the weather. For example, leakage from the roof above the condenser can cause external corrosion.

**APPENDIX 1: LOCATIONS SAFETY DEVICES CONDENSER**

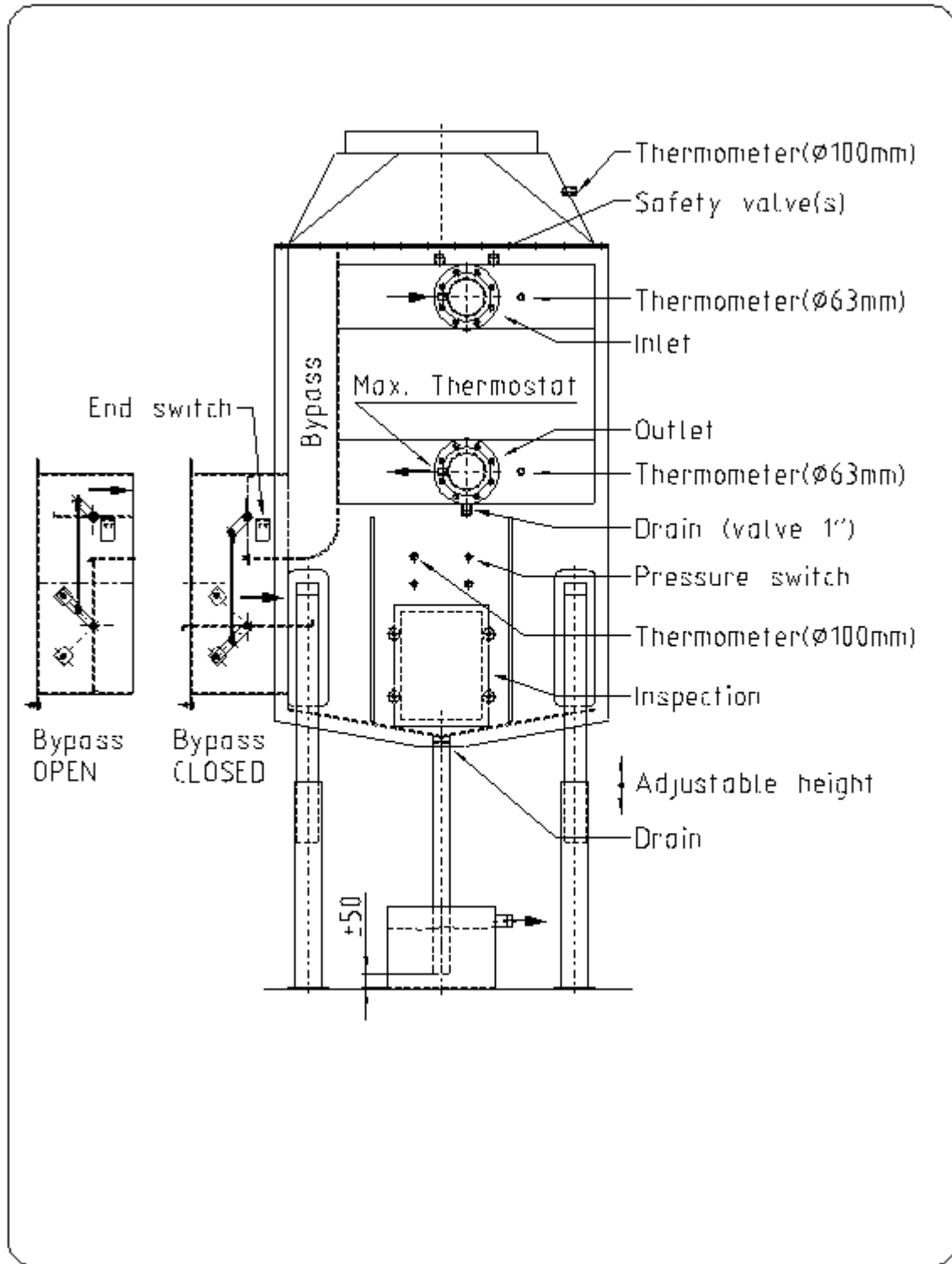



## **APPENDIX 2: REQUIREMENTS WATER QUALITY HEATING BOILERS**

### **Oxygen content and hardness**

The amount of make-up water supplied to the heating system determines, among other things, the oxygen content and hardness of the water. The heating system must therefore be regularly checked for leaks and any leaks that may occur must be detected and remedied without delay.

### **Oxygen**

As little oxygen as possible should enter the system. A source of oxygen uptake is diffusion through gaskets, O-rings, plastic, and the like. This form of oxygen uptake cannot be prevented, which is why corrosion prevention measures sometimes remain necessary.

### **Hardness**

Calcium is formed when the water in the boiler is heated.

To get an idea whether the amount of lime that comes from a certain water type with a certain water supplementation can cause problems for the boiler, the formula below can be used.

Scale number	=	$tH \times (5 \times S_j + I) / Q_k$
Whereas:	tH	= Temporary hardness in ° DH (easy to measure with test set for temporary hardness).
	S <sub>j</sub>	= Annual make-up water quantity (water meter installation in the make-up line is therefore absolutely necessary).
	I	= Content of the total system in m <sup>3</sup> .
	Q <sub>k</sub>	= Boilercapacity in kW

If this calculation gives a result <0.25, then the chance of scaling that is dangerous for the boiler will be low. If the number is > 0.25, (partial) softening is recommended.

The system water must not be noticeably thickened (for example due to the escape of steam) because the chloride content in this water may not be more than 10% higher than in the make-up water.

## **INSTALLATIONWATER**

Checking the quality of the installation water, at least once a year, is recommended.

If this is done by an expert, he will also provide an assessment of that water and, if necessary, issue an opinion as to whether or not treatment is or becomes necessary. Under no circumstances may the following values be exceeded. (In case of pH the value may also not be lower than recommended value)

Solids (sludge)	:	absent or very small amount
pH	:	9 - 10 (in the presence of Aluminium 8 - 9)
Hardness	:	< 0,1 °DH
p-number/l	:	0,5 - 2 mval/l
m-numner	:	< 2 p-getal
Oxygen O <sub>2</sub>	:	< 0,1 mg/l
Conductivity	:	without additives < 1000 µS/cm
Cl	:	< 100 mg/l
Hydrazine	:	absent due to carcinogenicity
Phosphate PO <sub>4</sub>	:	20 - 50 mg/l
Sulfate SO <sub>4</sub>	:	< 100 mg/l

If chemicals need to be dosed, this should only be done by experts. Other treatment products on supplier's advice.

### **APPENDIX 3: PERMITTED (MANDATORY) SAFETY EQUIPMENT**

The security equipment supplied by F&H Crone must be mounted at the indicated positions according Appendix 1

The equipment to be used are:

- Safety relief valve(s): UV stamped 1.1/4"
- Maximum thermostat: type RAK-TW-1000HB (Siemens)
- Pressure switch: GW10A4 (Dungs)
- End switch: LS-11S (EATON)

## APPENDIX 4: DATASHEET CONDENSER

		Type Condenser (single waterside circuit)														
		L6C	L12C	L18C	L24C	L30C	L36C	L42C	L48C	L60C	L72C	L84C	L96C	L108C	L120C	L140C
<b>Flue gas condenser serie Excellent ASME</b>																
Technical data																
Boiler capacity	kW	600	1200	1800	2400	3000	3600	4200	4800	6000	7200	8400	9600	10800	12000	14000
Max Condenser capacity at watertemp 45-35°C	kW	140	198	326	349	395	488	558	663	791	895	1023	1139	1395	1453	1569
VO (heating area)	m <sup>2</sup>									521	605		783	845	1010	1147
Watervolume (content)	ltr									545	560		730	815	840	975
Transportweight	kg									2570	2810		3570	3760	4120	4525
Transportdimensie L	mm									1870	1870		2000	2485	2785	2801
Transportdimensie W	mm									2145	2345		2472	2115	2115	2147
Transportdimensie (with exhaust hood) H1	mm									2702	2711		2732	2774	2774	2786
Transportdimensie (without exhaust hood) H2	mm									2216	2225		2246	2238	2238	2250
Watersided connections (150#)										2x 5"	2x 5"	2x 6"	2x 6"	2x 6"	2x 6"	2x 6"
Safety valve connection										2x 1"	2x 1"	2x 1.1/4"	2x 1.1/4"	2x 1.1/4"	2x 1.1/4"	4x 1"
Safety valve connection outlet (NPT male)		1x 1.1/4"	1x 1.1/4"	1x 1.1/4"	1x 1.1/4"	1x 1.1/4"	1x 1.1/4"	2x 1.1/4"	2x 1.1/4"	2x 1.1/4"	3x 1.1/4"	3x 1.1/4"	3x 1.1/4"	3x 1.1/4"	4x 1.1/2"	4x 1.1/2"
Drain connection		1"	1"	1"	1"	1"	1"	1"	1"	1"	1"	1"	1"	1"	1"	1"
Condensate bin overflow connection		1.1/2"	1.1/2"	1.1/2"	1.1/2"	1.1/2"	1.1/2"	1.1/2"	1.1/2"	1.1/2"	1.1/2"	1.1/2"	1.1/2"	1.1/2"	3"	3"
Chimney connection (Ø)	mm	200	300	350	450	500	550	600	600	650	700	710	800	850	950	950
Fluegas inlet connection (square)	mm	400	400	500	500	600	600	700	700	800	800	800	900	900	900	1000
Flue gas flow (volume)	Nm <sup>3</sup> /h	807	1614	2421	3228	4034	4414	5648	6455	8069	9683	11297	12910	14524	16138	18828
Fluegas inlet temperature	°C	180	180	180	180	180	180	180	180	180	180	180	180	180	180	180
Fluegas outlet temperature (at water inlet 35°)	°C	46	46	46	46	46	46	46	46	46	46	46	46	46	46	46
Fluegas sided resistance	Pa	250	300	400	400	400	450	450	450	450	500	500	500	500	500	500
Fluegas sided resistance	mm w.k	25	30	40	40	40	45	45	45	45	50	50	50	50	50	50
Max water temperature	°C	95	95	95	95	95	95	95	95	95	95	95	95	95	95	95
Max water design pressure	bar(g)	3	3	3	3	3	3	3	3	3	3	3	3	3	3	3
Water flow (volume)	m <sup>3</sup> /h	12	17	28	30	34	42	48	57	68	77	88	98	120	125	135
Water inlet temperature	°C	35	35	35	35	35	35	35	35	35	35	35	35	35	35	35
Water outlet temperature	°C	41	43	45	45	45	45	45	45	45	45	45	45	45	45	45
Water sided resistance	kPa	3,8	4	4,4	4,7	5,2	5,4	5,7	6	6	6	6,7	7	7	8	9

Including delivery (per condenser) of:  
 1x Pressure switch for flue gas box, incl stainless steel 90° elbow  
 1x Limit switch for flue gas box diverter valve  
 1x Max. Thermostat for water temperature  
 2x Thermometer Ø100 mm, 0-200°C (for flue gas in/out)  
 2x Thermometer Ø60 mm, 0-120°C (for flue gas in/out)  
 Safety valve(s), outlet connection NPT female  
 Ball valve (drain) 1" outlet connection BSP female  
 Pipe Ø60 for condensate discharge  
 Supports for condenser (100x100 mm)  
 Condensate bin Aluminium, overflow connection BSP male